

RacloFlex 



**Belt scraper / Auto-adaptative curved mono-blade secondary belt scraper**



# WHY CHOOSE THE RACLOFLEX SW ?

A unique and innovative scraper

## + An ingenious system that adapts to your belt

The **RacloFlex Sw** has a blade with two inserts that transfers the lateral external pressures to an increased central pressure. Therefore, the scraper adapts automatically and compensates its wear continuously. This guarantees maximum efficiency and lifetime, with minimum maintenance. Standard features includes tungsten carbide 3x15mm high quality 93 HRa.

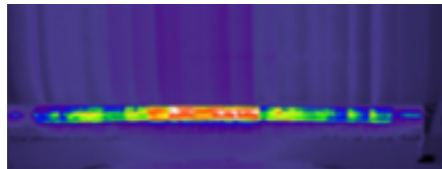

Thermal imaging system for scraping pressure

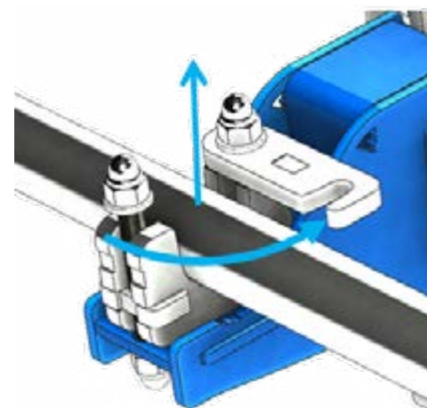
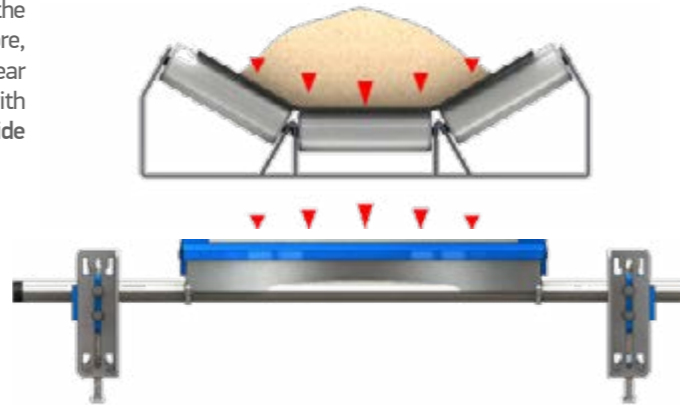

## ADVANTAGES

- Easy installation
- Longer lifespan
- Anti-clogging design
- Minimum maintenance
- Fast opening bearing
- Easy and compact
- Galvanised metal parts
- Very high cleaning performance
- Curved blade attached without adjustment
- Very few screws
- Retractable pressure rod
- Solid mechanism for a reasonable weight
- Graduated shock absorbers, with cogs and non-return

## + OPTIONS, ACCESSORIES AND VERSIONS

### Pulling pressure

Allows the Scraper pressure to be adjusted from above and within the location angle.



### Special «MultiTool key»

Performs all the necessary functions for the manipulation and settings of the scraper.



### Adjusting bracket

Enables you to cut and weld the support tube to reposition the blade with respect to the support mounts.



## + General information for the RacloFlex Sw

<b>Blade Quality:</b>	Tungsten Carbide : 93 HRA 3x15mm
	Or- Tungsten Carbide : 93 HRA 5x20mm
	Or- Impact Carbide : 66 HRA 5x10mm (Compatible with SUPER-SCREW® / ISC® / FIX'N GO®)
	Or- Wear resistant Polyurethane : 25mm <sup>3</sup> svt DIN53516-10N (Compatible with SUPER-SCREW® / ISC® / FIX'N GO®)
<b>Working position:</b>	Scraping angle = 90° (see notice) « spoon » blades and front shock absorbers
<b>Surface treatment:</b>	All electro-galvanized steel pieces or painted + A2 grade Stainless bolts
<b>Temperature:</b>	0° / + 50° C
<b>pH Range:</b>	3 to 11
<b>Maximum speed:</b>	SW 1 way = 3 m/s SW -HD 1 way = 5 m/s
<b>Avoid exposure to:</b>	Impact and staples on tungsten carbide and ceramic Hot water steam : special quality available Corrosive atmosphere : Stainless Steel is possible on all or part Uncontrolled fouling on entire scraper

<b>Belt, mm</b>	400	500	650	800	1000	1200	1400	1600	1800	2000	2200
<b>Scraping width SW, mm</b>	400	500	630	750	950	1150	1300				
<b>Tungsten width SW, mm</b>	315	395	520	640	800	960	1120				
<b>Scraping width SW-HD, mm</b>					950	1150	1300	1500	1700	1900	2100
<b>Tungsten width SW-HD, mm</b>					840	1040	1200	1400	1600	1800	2000

For any request of a scraper to suit greater than 2200 mm belt, the scraper will be manufactured to order.

## + Typical application of RacloFlex Z<sup>2</sup> in conjunction with a Primary Scraper

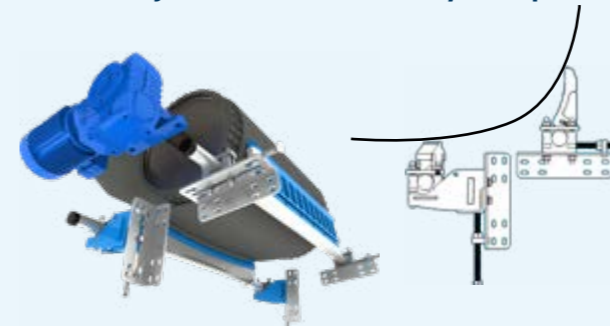

## + RacloFlex Sw-HD

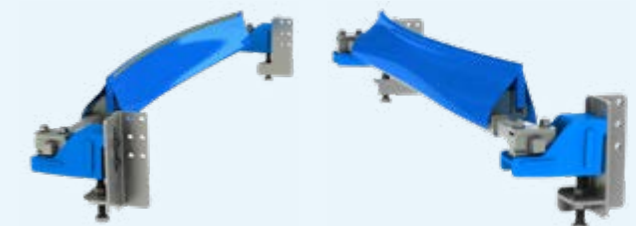

Heavy version **RacloFlex Sw HD** recommended for belts from 1400 to 2200 : Tungsten carbide 5x20, big flexible profiles and reinforced mechanism.



RacloFlex Sw

**MLT Conveyor Solutions Expert**  
More than 70 years of innovation  
at your service



 **MLT GROUP**  
Conveyor Solutions Expert

[www.mltgroup-conveyor.com](http://www.mltgroup-conveyor.com) - [info@mltgroup-conveyor.com](mailto:info@mltgroup-conveyor.com)

SW 27/09/2022